

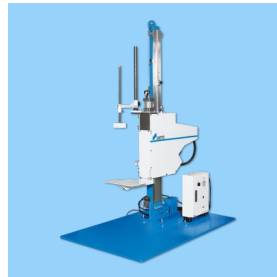

Testing system and measurement instruments
supporting the transportation safety and product reliability improvement



CATALOG



SHINYEI TESTING MACHINERY CO., LTD.

www.shinyei-tm.com



Testing and Measuring Technique for Safety and Reliability of Product and Distribution

We, SHINYEI TESTING MACHINERY CO., LTD., were founded in 2015 in Japan. We provide drop tester for packaging freight, shock testing system to determine to product reliability and measurement instruments in the distribution field which has launched since 1946 as Yoshida Seiki corporation.

Recently, the risk of damage to the mobile products or packaged freight during distribution or usage situations has increased, because of the variety of mobile products that have been developed, the diverse delivery system used in wide-spread internet shopping. In these circumstances, to improve product and packaging design, we provide services such as drop/shock testing systems, technical seminars and consulting services.

We contribute to building an affluent society by bringing you safety and reliability with our products and services based on the accumulated achievements and testing expertise.



Company Profile

Company Name	SHINYEI TESTING MACHINERY CO.,LTD.
Head Office/Testing Laboratory	B47 city block 11plot, Katoridai, Tsukuba, Ibaraki, 300-2657, JAPAN TEL. +81-29-848-3570 (Rep.) TEL. +81-29-848-3571 (Sales) FAX. +81-29-848-3572 URL: http://www.shinyei-tm.com
Kobe Office	Shinyei BLDG.5F, 77-1, Kyomachi, Chuoku, Kobe, 650-0034, JAPAN TEL. +81-78-392-6963 FAX. +81-78-332-1619
Nagoya Office	Nishiki MI BLDG.6F, 1-7-39, Nishiki, Nakaku, Nagoya, 460-0003, JAPAN TEL. +81-52-218-5472 FAX. +81-52-218-6110
Foundation	February 2015
Capital	50million yen
Director	Representative Director : Shinichi Shibata Managing Director : Hiroshi Taniguchi Director : Bunya Koyama Director : Yoshinori Sasaki Auditor : Masato Takai



INDEX

SHOCK MACHINE

PDST series	< P.3 >
HDST series	< P.5 >
ASQ series	< P.7 >
MDST series	< P.8 >
SDST series	< P.9 >
SHOCK MACHINE option	< P.10 >
PST-300	< P.11 >
CDS series	< P.12 >

DROP TESTER for mobile products

DT-202 series	< P.13 >
DT-205 series	< P.14 >
DT-202,DT-205 option	< P.15 >
RDT series	< P.16 >

DROP TESTER for packaged freight

DTS series	< P.17 >
DT-80M	< P.18 >
DT-20e series	< P.19 >
DT-300 series	< P.20 >
EMH series	< P.20 >

MATERIAL TESTING SYSTEM

ACST series	< P.21 >
CT series	< P.22 >

TRANSPORTATION TESTER

BF-50UT	< P.23 >
BF-100UT	< P.24 >

ACCELERATION MEASUREMENT

SM-500	< P.25 >
AccStick	< P.27 >

FIELD DATA RECORDER

DER-1000	< P.29 >
FIR-106	< P.30 >
G-MEN series	< P.30 >

SHOCK TOWER

PDST-230 series

Shock Testing System

PDST-230M, 230S

PDST-230 is a new mechanical based shock testing system in which the shock table is pulled-down mechanically, with compact built that is able to conduct mechanical shock test on to smartphones, tablets, computers and other devices. This new shock machine meets a wide range of requirements for shock testing and with compact size is easily installed in various location.

Features

- Pull-down type shock machine (patent pending)
- Compact size (about 50% downsizing comparison with the conventional free-fall style shock machine)
- Shock pulse up to $300,000\text{m/s}^2$ (30,000G) by dual-shock amplifier
- Selectable of 2 models (multi-shock generator or single cushioning pad)
- High repeatability
- Safety accessories are standard equipment

Compliance Standard

- IEC 60068-2-27
- JEDEC (JESD22-B111)
- JEITA (ET-7409/106)
- MIL-STD-810
- JIS C 60068-2-27



PDST-230M

Specification

Model	PDST-230M	PDST-230S
Table size (mm)	236 × 236	
Testable mass (kg)	up to 20	
Shock pulse shape	Half-sine	
Shock acceleration range (m/s^2)	490 ~ 7840 (50 ~ 800G)	1470 ~ 22540 (150 ~ 2300G)
Optional shock acceleration range (m/s^2)	98,000 (10000G) ~ 294,000 (30,000G) with 0.07~0.2ms *HGP150 use	
Pulse duration range (ms)	2.5 ~ 20 (multi-shock generator)	0.5 / 1 / 3 (single cushioning pad) * select 1 in 3 programmers
Velocity change (m/s)	15 max.	
Base	Pneumatic springs and hydraulic damper device	
Break system	Pneumatic-hydraulic brake system	
Test mode	Single shot / Multi-shock mode	
Size (W × D × H mm)	650 × 800 × 1800	
Capacity (kg)	1500	
Power supply	100 ~ 240VAC	
Air supply	over 0.8MPa and 350dm ³	
Option	Shock programmers (duration is 0.5ms / 1ms / 3ms), Shock Manager SM-500, Dual-shock amplifier HGP series, Signal light for safety, Air compressor, Acceleration pick-up	

Accurate Shock Pulse

Generated shock pulse on PDST is always clear, noiseless and with high repeatability of up to 300000m/s^2 (30000G) with the optional dual shock amplifier, HGP-150.

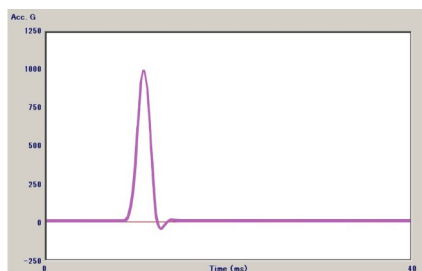

1000G@2.5ms

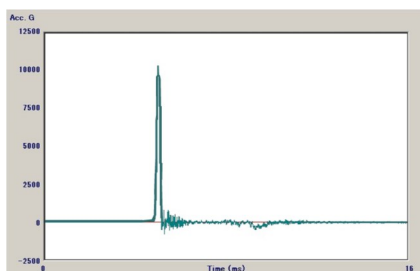

10000G@0.2ms



HGP-150

Built in Multi-Shock Generator

Multi-shock generator (MSG, see the figures below), technology unique to us, for shock tests, is built into the PDST-230M.

In a general shock machine, the duration of a shock pulse corresponds to the hardness of the shock programmer. This means the programmer needs to be changed if you require a different duration of the shock pulse.

However, the MSG is a mechanical based function of the shock machine that can modify the displacement of the shock programmer by changing the height of the metal ring. Therefore, the generated shock duration of the shock pulse on the MSG is variable between short to long with the use of only a single shock programmer. This will contribute to the efficiency of conducting shock tests and is relatively stress-free for the testing engineers.

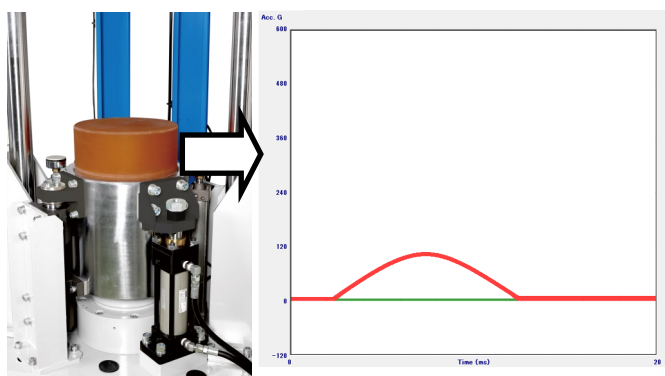

MSG programmer with high exposure generates shock pulse with long duration.

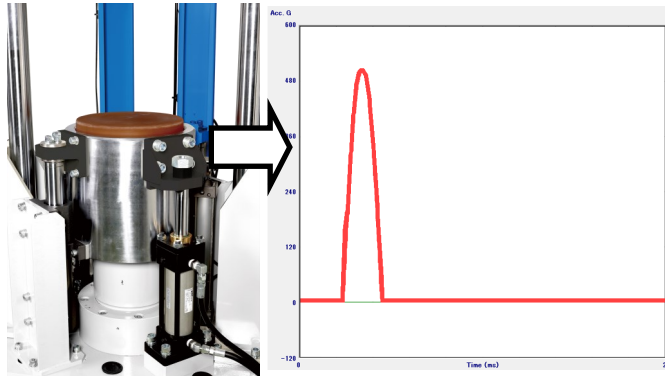

MSG programmer with low exposure generates shock pulse with short duration.

Compact Body

Although the PDST body size is very compact when comparing with the conventional free-fall style shock machines, its performance is almost identical to them because the PDST has a unique function in which the shock table is pulled down vertically mechanically.

This model can be installed easily in various locations as its area and volume are dramatically smaller than conventional models.



SHOCK TOWER

HDST series

High Speed Shock Testing System

HDST-150, 230, 300

HDST is the best option in Shock Machine's to ensure products such as smartphones, tablets, computers and other mobile devices are able to withstand shock. By applying high acceleration to computer parts, smart phones, tablets, laptops, cellular phones, and various mobile products to conduct product fragility test.

Features

- Specialized for High Acceleration up to 294000m/s² (30000G)*
 - High Reproducibility
 - Easy Maintenance for Long Term Durability
 - Easy-to-Use Test Settings by the Simple Construction
 - Set-up by Double-Layered Shock Absorber
- * with Dual Mass Shock Amplifiers HGP (Option)

Compliance Standard

- IEC 60068-2-27-87
- JEDEC (JESD22-B111)
- JEITA (ET-7409/106)
- MIL-STD-810F
- JIS C 60068-2-27

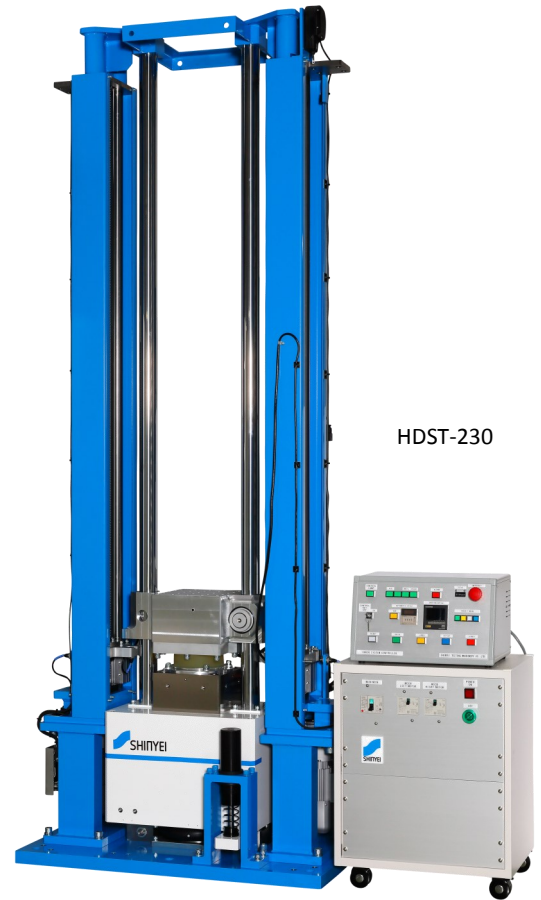

Specification

Model	HDST-150	HDST-230	HDST-230HS	HDST-300
Table size (mm)	150 × 160	230 × 230	230 × 230	300 × 300
Specimen max weight (kg)	1	10	5	20
Shock pulse	Half-sine			
Acceleration range (m/s ²)	14700 (1500G)	29400 (3000G)	49000 (5000G)	29400 (3000G)
Pulse duration range (ms)	0.5 / 1.0	0.5 / 1.0 / 2.0		
Seismic base	Pneumatic springs and hydraulic damper device			
Brake mechanism	Pneumatic-hydraulic friction brake system			
Controller	Manual & auto cycle control			
Size (W × D × H mm)	1000 × 800 × 2330	1000 × 600 × 2675	1000 × 600 × 3970	1100 × 640 × 2700
Capacity (kg)	600	1200	1400	1500
Controller Size (W × D × H mm)	520 × 400 × 950	520 × 400 × 950	520 × 400 × 950	520 × 400 × 950
Power supply	200V-10A			

* (Available for customization) The above are standard specifications. Please contact us if you have any request to customize.

Options for HDST series

Dual Mass Shock Amplifiers HGP series

for generating extremely high acceleration levels.

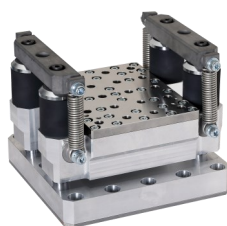
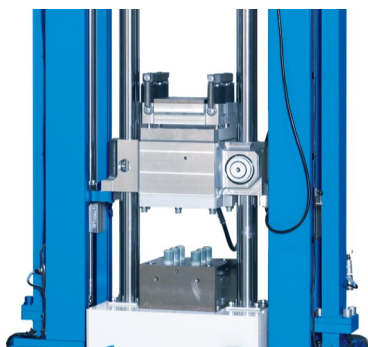

HGP-150

HDST-230 with HGP-150

Combination with shock testing system

Designed to be paired with shock testing systems, especially with HDST-series, for generating up to 294000m/s^2 (30000G). Depending on desired acceleration, it can also be applied to other testing systems.

Well controlled test

With its simple construction, it can be easily affixed on the shock table of the shock tester to carry out tests. The acceleration is well controlled.

Specification (Standard model)

Model	HGP-20	HGP-150
Test sample table size	W170 × D160	W150 × D150
Test sample max. weight	3	5
Shock acceleration range (m/s^2)*	2000 ~ 50000 (200 ~ 5000G)	90000 ~ 460000 (9000 ~ 50000G)
Pulse duration range (ms)	0.2 ~ 1	0.08 ~ 0.2

* Customized model available

Example usage of the HGP-150

Specimen: Module for Mobile Phone

Acceleration & Duration:

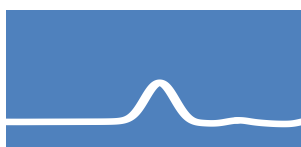

① 147000 m/s^2 (15000G)
@0.15ms



② 294000 m/s^2 (30000G)
@0.07ms

Shock Manager SM-500

It can contribute to the measurement and analysis of shock test. It is able to incorporate a max of 10 channels of accelerometers* and assist in monitoring its test result. With useful functions like SR and SRS analysis, it can analyze various specimens.



- User-Friendly Operation
- Multi analyzing functions

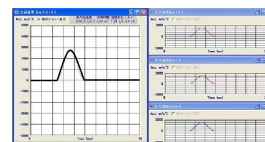

*10 channels for only the piezoelectric orbuilt-in amplifier type
5 channels each for the piezoelectric and build-in amplifier type (Total 10 channels)

Safety Installations

The test should be carried out not only correctly, but also safely. These installations contribute in assuring its safety.

- Safety Fence (soundproofing)
To lower external noise levels and prevents injuries during tests. It covers the whole tester. When the door is closed, those risks would be reduced.
- Signal Light
Its color changes corresponding to the action at that point of time. These changes can announce the situation of tester to whoever is around the tester.
- Safety Mat Switch
This mat surrounds the tester and stops the movement when anything is on it.
Its size and quantity can be arrange as per required.
- Photoelectric Sensor
It detects anything that cuts off its photoelectric range. These sensors need minimal space to install and keeps high sensitivity.



Safety Fence

*Available to apply either requirement.

SHOCK MACHINE

ASQ series

Automatic Square Drop Shock Tester

ASQ-500, 700, 900, 1100, 1500

ASQ is the best application shock machine which not only can apply half-sine wave, but also trapezoidal wave. Damage Boundary Curve will also be described from this testing system. In addition, this model has a "Multi-shock pulse generator", to generate multi shock test conditions, changeable shock durations, by a single programmer.

Features

- Half-sine and Trapezoidal pulse generator
- Multi shock pulse generator
- Simple setting by auto-control system
- Damage Boundary Test
- High Reproducibility
- Easy Maintenance for Long Term Usage
- Set-up by Double-Layered Shock Absorber

Compliance Standard

- IEC 60068-2-27
- JIS C 60068-2-27, Z 0119-94, Z 0202-94
- MIL-STD-810E-89 516.3
- ASTM D3332, D5487

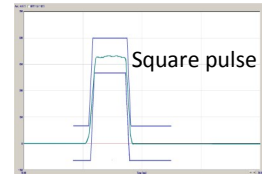

ASQ-1500

Specification

Model	ASQ-500	ASQ-700	ASQ-900	ASQ-1100	ASQ-1500
Maximum drop height (mm)	1500				
Table size (W × D mm)	500 × 500	700 × 700	920 × 920	1150 × 1150	1500 × 1500
Specimen max weight (kg)	75	100	200	300	500
Shock pulse	Trapezoidal and half-sine				
Acceleration range Half-sine (m/s ²)	5880 (600G) *1			4900 (500G)	
Trapezoidal (m/s ²)	1470 (150G)				1100 (110G)
Max. velocity change Half-sine (m/s)	7.6 *1	8.4 *1	7.5	5.9	5.0
Trapezoidal (m/s)	7.3	8.0	7.0	8.0	8.0
Pulse duration range Half-sine (ms)	4 ~ 25 *1		2.5 / 6 / 11 / 20 (Multi-shock programmer available)		
Trapezoidal (ms)	6 ~ 60		6 - 55	6 ~ 60	
Size (W × D × H mm) *2	1300 × 700 × 2950	1600 × 900 × 3180	1800 × 1150 × 3240	2200 × 1300 × 3300	2500 × 1800 × 3300
Weight (kg) *2	1800	4170	5800	9000	15000
Seismic base	Pneumatic spring and hydraulic damper device				
Brake mechanism	Pneumatic-hydraulic friction brake system				
Controller	a. Operation control (security) b. Automatic operation setting control section c. Waveform measuring indicator d. Power supply & compressor				
Controller size (W × D × H mm)	575 × 750 × 820 *2				
Power supply	AC200V, 3 phase, 20A				

*1 using a multi-shock duration programmer

*2 by normal spec.

* (Available for customization) The above are standard specifications. Please contact us if you have any request to customize.

SHOCK MACHINE

Multi-Drop Shock Testing System

MDST-300, 500, 700, 900, 1100, 1500, 2000

MDST has a unique characteristic, called the “Multi-shock pulse generator” to apply multi shock test conditions via a single programmer. With that characteristic and a wide range of table sizes, this tester can be used for various specimens.

Features

- Multi test-conditions application
- High Reproducibility
- Easy Maintenance for Long Term Usage
- No-brainer Tester to operate
- Easy Setting with Simple Construction
- Set-up by Double-Layered Shock Absorber

Compliance Standard

- IEC 60068-2-27
- JIS C 60068-2-27
- MIL-STD-810E
- JIS Z0202, ASTM D5487(with optional programmer)

MDST series



MDST-500

Specification

Model	MDST-300	MDST-500	MDST-700	MDST-900	MDST-1100	MDST-1500	MDST-2000
Table size (W × D mm)	300 × 300	500 × 500	700 × 700	920 × 920	1150 × 1150	1500 × 1500	2000 × 2000
Specimen max weight (kg)	50	80	100	200	350	500	500
Shock pulse	Half-sine						
Acceleration range (m/s ²)	100 ~ 3000 (10 ~ 300G)				100 ~ 2700 (10 ~ 270G)		100 ~ 2000 (10 ~ 200G)
Pulse duration range (ms)	4 ~ 25						
Size (W × D × H mm)	1100×640×2400	1300 × 700 × 2500	1600 × 900 × 2950	1800 × 1150 × 3300	2200 × 1300 × 3100	2500 × 1650 × 4055	3000 × 2300 × 3690
Capacity (kg)	1000	2600	4200	5200	9000	19100	32000
Controller size (W × D × H mm)	520 × 500 × 950						
Power supply (Voltage)	AC200V, 3-phasese, 10A		AC200V, 3-phasese, 20A		AC200V, 3-phasese, 30A		AC200V, 3-phasese, 40A
Power supply (Current consumption)	10A		20A		30A		40A

* (Available for customization) The above are standard specifications. Please contact us if you have any request to customize.

SHOCK MACHINE

SDST series

Single-Drop Shock Testing System

SDST-300, 500, 700, 900, 1100, 1500

SDST is specialized for carrying out some specified shock test conditions by simplifying the programmer system. This tester can apply various conditions by changing the programmer just by replacing it. This is the simplest model in our shock machine series.

Features

- High Reproducibility
- Easy Maintenance for Long Term Usage
- Easy-to-Use Test Settings
- Simple Setting by Simple Construction
- Set-up by Double-Layered Shock Absorber

Compliance Standard

- IEC 60068-2-27
- JIS C 60068-2-27
- MIL-STD-810E
- JIS Z0202, ASTM D5487 (with optional programmer)

Specification

Model	SDST-300	SDST-500	SDST-700	SDST-900	SDST-1100	SDST-1500
Table size (mm)	300 × 300	500 × 500	700 × 700	920 × 920	1150 × 1150	1500 × 1500
Specimen max weight (kg)	50	80	100	200	300	500
Shock pulse	Half-sine					
Acceleration range (m/s ²)	100 ~ 3000 (10 ~ 300G)					
Pulse duration range (ms)	3 / 6 / 11 / 20					
Size (W × D × H mm)	1100 × 640 × 2300	1300 × 700 × 2400	1600 × 900 × 2900	1800 × 1150 × 3200	2200 × 1300 × 3300	2500 × 1800 × 4100
Capacity (kg)	900	2500	4000	5000	9000	12000
Controller size (W × D × H mm)	520 × 400 × 950					
Power supply	AC200V, 3-phasese, 10A		AC200V, 3-phasese, 15A		AC200V, 3-phasese, 20A	



SDST-700

SDST-1500

* (Available for customization) The above are standard specifications. Please contact us if you have any request to customize.

Option for SHOCK MACHINE (ASQ / MDST / SDST)

Automatic System of "rubber-height changeable device" (ASQ/MDST only)

This system makes it possible to apply wide range test conditions by controlling the height of rubber automatically. Although this system is usually a manual changeable system, the automatic system can be selected upon request. This system will assist in conducting the shock test stress-free.

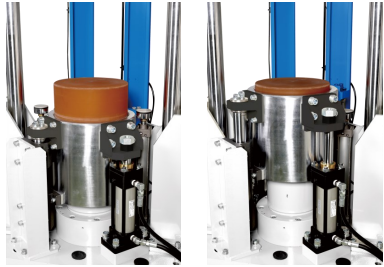

"low-impulse generator" System

To apply low acceleration, this system controls drop speed of drop table by making it slower. It generates lower acceleration which can hardly be applied by standard models.

High speed lifting system

By implementing the high speed lifting system via wire and electromagnet, the test cycle becomes almost twice quicker than the standard model. For large amounts of continuous test, this contributes to shortening the time to test effectively.

Customizable table size

For various specimen sizes, we can customize the table to a larger size while taking into consideration the whole balance. Our record for the maximum size is 2000×2000mm.

Specialized Programmer for Drop Test of Packaging

Short duration programmer with less than 3msec is selectable optionally. The equivalent drop test for packaging, based on ASTM D5487, via the shock machine can be conducted using this programmer.

Shock Amplifier, HGP series

This device can generate the high amplitude shock pulse by collaborating with the shock machine. There are 2 type of amplifier, HGP-20 up to 5,000G with 0.2ms duration, and HGP-120 up to 30,000G with 0.1ms.

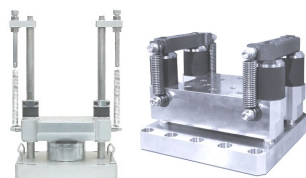

HGP-20

HGP-150

Shock Manager SM-500

It can contribute to the measurement and analysis of shock test. It is able to incorporate a max of 10 channels of accelerometers* and assist in monitoring its test result. With useful functions like SR and SRS analysis, it can analyze various specimens.



- User-Friendly Operation
- Multi analyzing functions

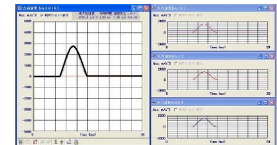

*10 channels for only the piezoelectric or build-in amplifier type
5 channels each for the piezoelectric and build-in amplifier type (Total 10 channels)

Safety Installations

The test should be carried out not only correctly, but also safely. These installations contribute in assuring its safety.

- Safety Fence (soundproofing)

To lower external noise levels and prevents injuries during tests. It covers the whole tester. When the door is closed, those risks would be reduced.



Safety Fence

- Signal Light

Its color changes corresponding to the action at that point of time. These changes can announce the situation of tester to whoever is around the tester.

- Safety Mat Switch

This mat surrounds the tester and stops the movement when anything is on it. Its size and quantity can be arrange as per required.

- Photoelectric Sensor

It detects anything that cuts off its photoelectric range. These sensors need minimal space to install and keeps high sensitivity.

*Available to apply either requirement.

SHOCK TESTER

Pendulum Shock Testing Machine

PST-300

PST-300 is very simple in construction and can be installed in tight spaces to conduct ideal shock test in any location. It is specialized to test small and light specimens, such as electronic components and medical products, with a wide range of acceleration.

Features

- Wide acceleration range between 50 ~ 50000m/s² (5 ~ 5000G)
- High reproducibility by pendulum mechanism
- Full automatic operation up to 9,999 times
- Easy maintenance for long term usage
- Easy-to-use test settings
- Simple setting by simple construction

Compliance Standard

- IEC 60068-2-27
- JEDEC JESD-22-B111
- MIL-STD-202, 750, 810, 883

Option for PST-300

- Shock measuring system SM-500
- Additional shock programmer

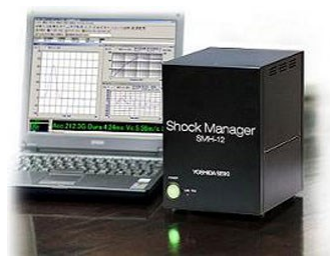

Shock Measuring System SM-500

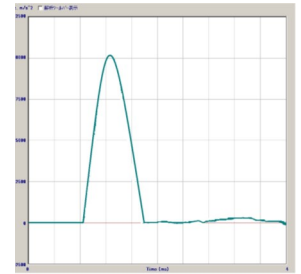

Shock pulse example, 1000G

Specification

Model	PST-300
Table size (mmφ)	100
Specimen max weight (g)	800
Shock pulse	Half-sine
Acceleration range (m/s ²)	50 ~ 50000 (5 ~ 5000G)
Pulse duration range (ms)	0.2 / 0.5 / 1 / 6 / 11
Brake device	Mounted
Control system	Single-turn and auto cycle operation
The number of process runs	1 ~ 9999
Set count in auto cycle	4 digits
One cycle in auto cycle	Max. 15 sec.
Size (W × D × H mm)	620 × 360 × 675
Capacity (kg)	100
Controller size(mm)	W380 × D250 × H220
Power supply	AC100V, 1A

BUMP TESTER

CDS series

Continuous Shock Testing System

CDS-50, 100

CDS is specialized to carry out continuous shock test by half-sine wave via cam drive mechanism, also known as bump test. It is mainly used for endurance testing of automotive parts like mirror, car audio, etc.

Features

- Specialized for continuous shock test
- High Reproducibility
- Easy Maintenance for Long Term Usage
- Easy-to-Use Test Settings by cam motion
- Simple Setting by Simple Construction
- Set-up by Single-Layered Shock Absorber

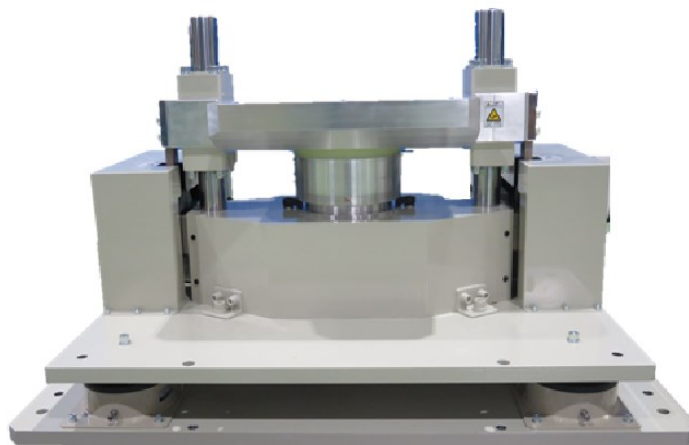

CDS-50

Compliance Standard

- IEC 60068-2-27
- JIS C 60068-2-27

Related Products

- Acceleration Measuring System SM-500

Specification

Model	CDS-50	CDS-100
Table size (mm)	500 × 500	1000 × 1000
Specimen max weight (kg)	50	100
Shock pulse	Half-sine	
Acceleration range (m/s ²)	60 ~ 1000 (6 ~ 100G)	
Repetition rate (per second)	1 ~ 3	1 ~ 2
Pulse duration (m/s)	2 / 6 / 16	
Control system	Automatic (1 ~ 99999 times) (by preset counter setting)	
Size (W × D × H mm)	1020 × 900 × 900	1700 × 1200 × 1080
Capacity (kg)	750	2800
Power supply	AC200V, 3-phasese, 600W	AC200V, 3-phasese, 2.5kw
Applied Standards	JIS C 60068-2-27, IEC 60068-2-27	

DROP TOWER

DT-202 series

Drop Tester for Mobile Products

DT-202, 202TB

DT-202 is a standard model of drop tester that provides accurate drop tests via a unique drop mechanism for smart phones, cell phones and other mobile products. The specimen holding system retains the dropping posture of specimens, enabling it to provide drop tests superior in reproducibility. DT-202TB is a wider sized drop tester. Its application is not only limited to the testing of mobile phones, but also extends to a broader variety of products such as laptop PC, tablet device, HDD, medicine, food etc.. Also this tester has the same drop system as DT-202 for accurate drop tests. These testers are CE certified.

Features

- Specialized for light and small specimens
- High Reproducibility
- Easy Maintenance for Long Term Usage
- Easy-to-Use Test Settings
- Easy-Installation to any Location
- Simple Setting by Simple Construction
- CE certified model

Compliance Standard

- IEC 60068-2-31
- JIS C 60068-2-31

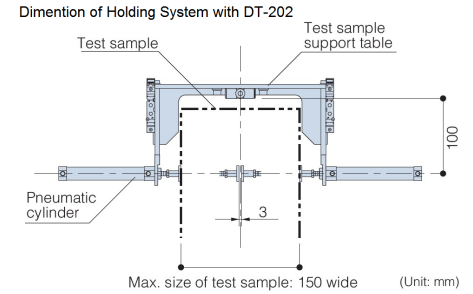

Dimension of Holding System with DT-202TB

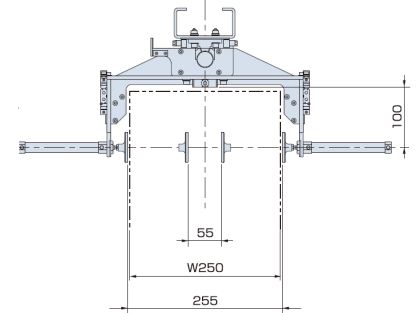

Specification

Model	DT-202	DT-202TB
Test sample maximum weight (kg)	2	
Drop height range (mm)	250 ~ 2000	
Drop height setting method	By the scale and setting guide	
Drop motion of test sample support table	By the permanent electromagnetic holder	
Fastening and releasing operation of test sample	By the pneumatic pen cylinder	
Dimension of tester (mm)	W600 × D500 × H2382	W600 × D616 × H2382
Mass of tester (kg)	about 80	
Base thickness (mm)	16	
Feed air pressure	0.49MPa or higher, 1.2dm ³ , (when operate 6 times/min) or more	0.49MPa or higher, 4.3L/min, (when operate 10 times/min) or more
Power supply	AC100 ~ 240V, single phase, 5A	
Operation environment temperature (°C)	5 ~ 35	

DROP TOWER

DT-205 series

Drop Tester for Mobile Products

DT-205, DT-205H

DT-205 / DT-205H are drop testers designed for products, containers and packaging materials, weighing up to 5kg. They can be used for drop testing in a broad variety of industrial products, including electronic devices such as notebook PC and HDDS, medical products, cosmetic and food products.

Features

- Specialization to light and small specimen
- High Reproducibility
- Easy Maintenance for Long Term Usage
- Easy-to-Use Test Settings
- Easy-Installation to any Location
- Simple Setting by Simple Construction

Compliance Standard

- IEC 60068-2-31
- JIS C 60068-2-31

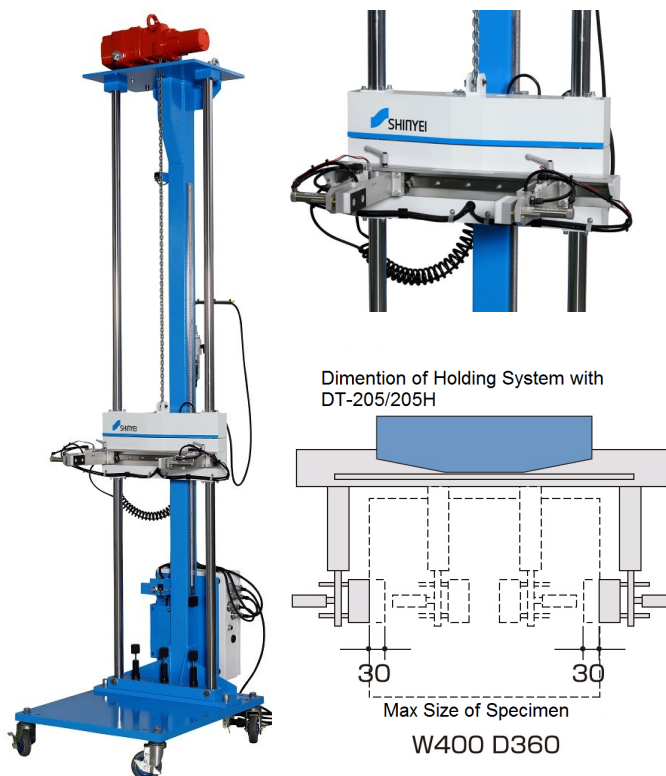

Specification

Model	DT-205	DT-205H
Specimen max weight (kg)	5	
Drop height range (mm)	500 ~ 1500 (posture holding fall) 250 ~ 1500 (free liberation fall)	500 ~ 2000 (posture holding fall) 250 ~ 2000 (free liberation fall)
Setting of drop height	Scale and pointer	
Falling motion of support table	By electric magnet	
Holding / Releasing specimen	Air pressure pen cylinder	
Size (W × D × H mm)	700 × 600 × 2400	900 × 800 × 3000
Weight (kg)	about 180	about 280
Power supply	AC100V, single phase, 5A	
Supply Air Pressure (MPa)	0.69 or more	
Usage environment temperature range (°C)	5 ~ 35 (JIS test location Standard temperature state Class 4)	

Options for DT-202, DT-205

Sample configuration of analysis system with high-speed camera

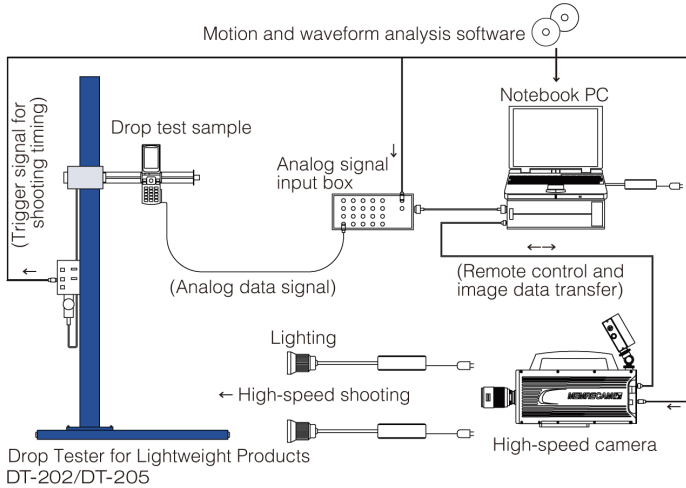

When an analysis system is built up using a high-speed camera, "shocks" can be observed visually. (High-speed shooting of a PCB under drop test)



• Plastic bottle



• Household detergent (Soft package)



• Cellular phone (Folding type)

Shock Manager SM-500

It can contribute to the measurement and analysis of shock test. It is able to incorporate a max of 10 channels of accelerometers* and assist in monitoring its test result. With useful functions like SR and SRS analysis, it can analyze various specimens .

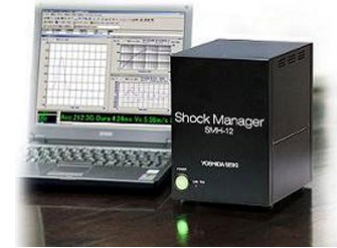

- User-Friendly Operation
- Multi analyzing functions

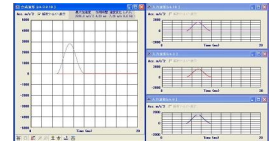

- *10 channels for only the piezoelectric or build-in amplifier type
- 5 channels each for the piezoelectric and build-in amplifier type (Total 10 channels)

Safety Installations

The test should be carried out not only correctly, but also safely. These installations contribute in to assuring its safety.

- Safety Fence (soundproofing)
To lower external noise levels and prevents injuries during tests. It covers the whole tester. When the door is closed, those risks would be reduced.
- Safety Mat Switch
This mat surrounds the tester and stops the movement when anything is on it.
Its size and quantity can be arrange as per required.
- Photoelectric Sensor
It detects anything that cuts off its photoelectric range. These sensors need minimal space to install and keeps high sensitivity.



Safety Fence

*Available to apply either requirements

DROP TESTER

RDT series

Rotating Drum Tester

RDT-1000

RDT-1000 can carry out continuous drop test for small electronic device such as smart phones, mobile phones. By utilizing the step less transmission controlling motor, it keeps high precision rotation of two different size drums at all time.

Features

- Applicable to various samples
- Safe operation with standard attached cover
- Less noise
- Easy Maintenance for Long Term Usage
- Easy-to-Use Test Settings
- Simple Setting by Simple Construction

Compliance Standard

- IEC 60068-2-31
- JIS C 60068-2-31



Specification

Model	RDT-1000
Specimen max weight (kg)	5
Drop height range (mm)	500 ~ 1000
Fall frequency (times per min)	5 ~ 20
The number of process runs	1 ~ 99999
Size (W × D × H mm)	1400 × 1600 × 1640
Size of controller (W × D × H mm)	520 × 400 × 550
Power supply	AC200V, 3 phases, 2kw

* (Available for customization) The above are standard specifications. Please contact us if you have any request to customize.

DROP TESTER

DTS series

High performance drop Tester for Packaged Freight

DTS-50, DTS-80

This is a high performance drop tester for packaging that has an air-driven cylinder and tension spring that functions by releasing the sample faster than the free falling speed, aiding the free falling of test sample. This system allows for a dramatic improvement in the falling posture of the test sample and a faster testing cycle. You can conduct accurate drop test using this model.

Features

- high accuracy drop test by vertical drop movement
- Specialized for packaged freight
- Wide range of test samples
- High Reproducibility
- Easy Maintenance for Long Term Usage
- Easy-to-Use Test Settings
- Simple Setting by Simple Construction

Compliance Standard

- ISO 2248
- JIS C 60068-2-31

Option for DTS

- Support Jig for corner/edge drop
- Basement for drop test at low height
- Safety installations (Safety fence, Mat-switch, Photoelectric Sensor)
- Shock acceleration measuring device Shock Manager(Model:SM-500)

Support Jig



Optional basement for low drop

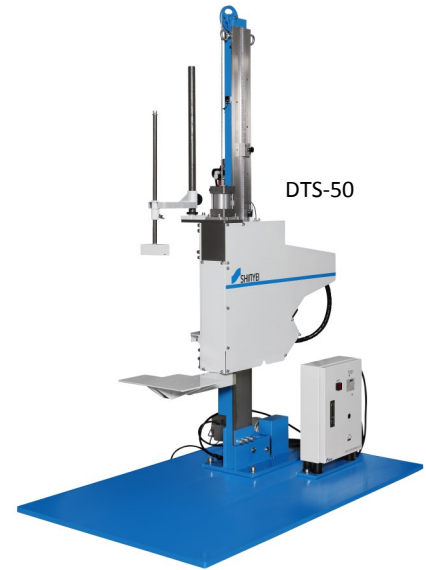
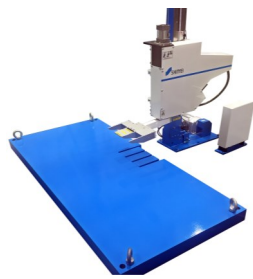

Accurate drop movement

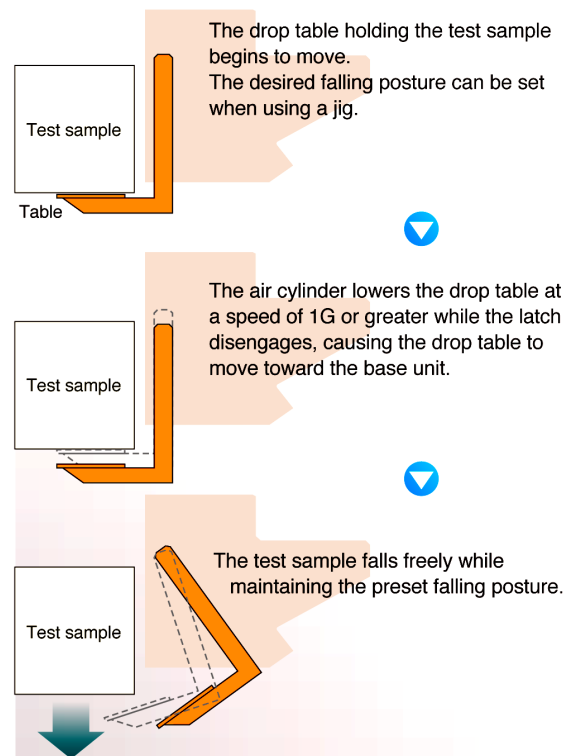

Specification

Model	DTS-50	DTS-80
Specimen max weight (kg)	50	80
Specimen max size (mm)	W900 × D510 × H900	W900 × D575 × H900
Drop height range (mm) *	200 ~ 1200	200 ~ 1800
Operation with drop test	High-speed vertical & rotational motion	
Capacity (kg)	300	420
Size (mm)	W920 × D1480 × H1975	W1000 × D1750 × H2583
Power supply	AC200V, 3 phases, 5A	
Air pressure (MPa)	0.6 or more	0.7 or more

* Depends on standard specification (Maximum drop height can be custom)

DROP TESTER

DT-80M

Standard Drop Tester for Packaged Freight

DT-80M

Drop Tester, DT-80M, is a standard model that is specialized for drop testing of packaged freight. Test specimens up to 80kg is dropped with high accuracy via a high speed rotational table that is operated from a drop height ranging from 20cm to 180cm automatically without air compressor. Now everyone can conduct drop tests based on compliance standards.

Features

- Standard model with easy functions
- Specialized for packaged freight
- High Repeatability
- Easy to use with automatic operation
- Easy Maintenance for Long Term Usage

Compliance Standard

- ISO 2248 , JIS Z 0202, JIS C 60068-2-31

Option for DT-80M

- Support Jig for corner/edge drop
- Shock Manager SM-500, Acceleration pick-up



Setting condition of package

Specification

Model	DT-80M
Specimen max weight (kg)*	80
Specimen max size (mm)	W900 × D575 × H900
Drop height range (mm) *	200 ~ 1800
Operation with drop test	High-speed rotational motion by spring
Capacity (kg)	320
Size (mm)	W920 × D1480 × H2583
Power supply**	AC200V, 3 phases, 5A

Actual article may be different from pictures.

*Customizable options. Please approach your local dealers for further information.

** Localized Power supply available on demand.

The desired falling posture can be set when using a jig (optional).

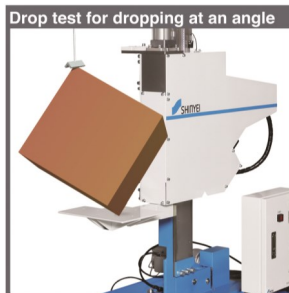
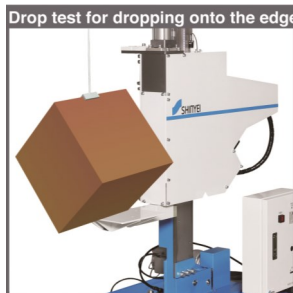
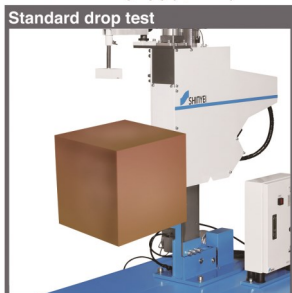

DROP TESTER

DT-20e

Drop Tester for Packaged Freight

DT-20e

DT-20e is a compact drop tester that can evaluate cushioning performance of compact packaging freight. This model is compact in size and can be installed to any location and is easy to use by anyone. You will be able to carry out drop testing for your packaging design anytime anywhere.

Features

- Specialized for small and light packaged freight
- compact to install
- low noise
- High Reproducibility
- Easy Maintenance for Long Term Usage
- Easy-to-Use Test Settings
- Simple Setting by Simple Construction

Compliance Standard

- ISO 2248
- IEC 60068-2-31



Dimension

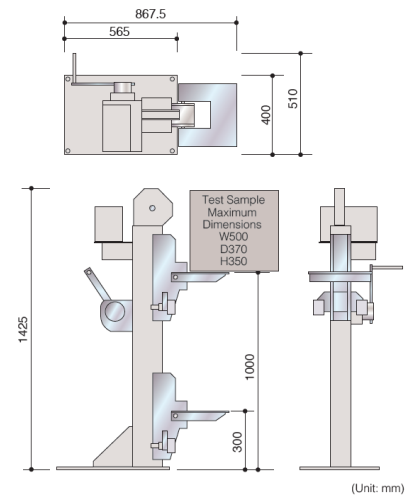

(Unit: mm)

Specification

Model	DT-20e
Specimen max weight (kg)	20
Specimen max size (mm)	W500 × D370 × H350
Drop height range (mm) *	300 ~ 1000
Drop motion	Drop table with high speed rotation
Weight (kg)	100
Size (W × D × H mm)	565 × 400 × 1425
Power supply	AC100 ~ 240V, 50/60Hz, 5A
Supply Air Pressure (MPa)	0.7 or more

* Set the drop height by hand winding winch (with brake)

DROP TESTER

Drop Tester for Packaged Freight

DT-300

DT-300 can aid in providing basic test for package specifications including cushioned package design, selection in packaging materials, fragility of packaged contents, standard test of packaged freights (surfaces only), etc. It can be performed efficiently with a high level of accuracy.

Features

- Free drop in precise posture
- Controlled drop height
- Anti-rebound drop table
- Safe operating conditions

Compliance Standard

- ISO 2248
- JIS Z 0200
- JIS Z 0202

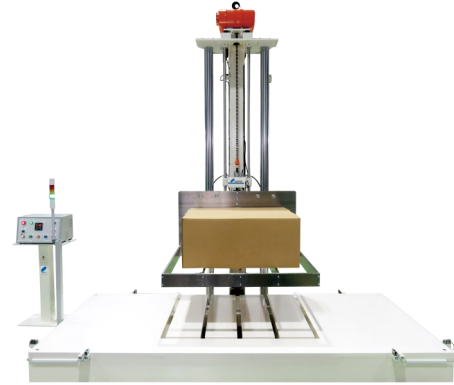

Specification

Model	DT-300
Specimen max size (mm)	W1600 × D1200 × H1500
Specimen max weight (kg)	300
Drop height range (mm)	50 ~ 1000
Drop attitude	Digital setup by a controller
Drop height setting	Digital setup by a controller
Brake of lifting table	Shock absorber and Counter-pressure brake
Size (mm)	W1700 × D1800 × H2600
Capacity (kg)	about 3600
Power supply	AC200V, 3 phases, 7A
Air pressure (MPa)	0.7 or more

DROP TESTER

Release Hook for Drop Test

EMH-500, EMH-3000

This model is a drop tester for heavy weight products and packaging. Massive cargo in packaged freight, unit load, palletized cargo, can conduct the drop test safely with the EMH. This well-designed electromagnetic hook can release the cargo for a steady drop test.

Note: the cage for hanging the EMH should be prepared by customer.

Features

- Specialized for massive samples
- No limit in size for the EMH-500
- High Reproducibility
- Easy Maintenance for Long Term Usage
- Easy-to-Use Test Settings
- Safe operation by energized operation

Compliance Standard

- ISO 2248
- JIS Z 0202



EMH-500
With specimen

Specification

Model	EMH-500	EMH-3000
Specimen range (kg)	1 ~ 500	50 ~ 3000
Capacity (kg)	about 12	about 40
Cable length of switch box (m)		5
Cable length of power box (m)		7
Power cable length (m)		3
Power supply	AC200V, single-phase, 1.5KVA	AC200V, single-phase, 3KVA

* The crane to hang the EMH tester is prepared for by the customer.

MATERIAL TESTING SYSTEM

ACST series

Dynamic Compression Tester for Cushioning Materials

ACST-200

ACST can conduct the dynamic compression test to identify the characteristics of cushioning materials. Shock response acceleration and displacement waveform of cushioning material are captured with ease when the compressive plate is dropped using this tester.

Features

- Easy operation with the automatic controller.
- Compressive plates for each mass are variable from 2.0kg to 50kg when in full spec.
- Velocity of drop plate also can be measured via optional indicator.
- With the specialized software, the characteristics of cushioning material is analyzed as stress-strain curve, cushion curve, cushion factor, etc. for practical use in the protective packaging design.

Compliance Standard

- ISO 4651
- ASTM D 1596-02 (2009)
- MIL-C-26861-87

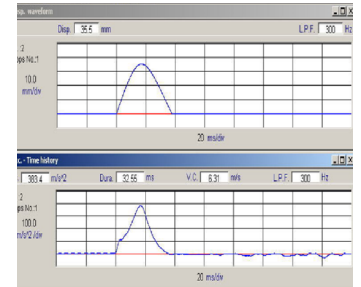

Acceleration and displacement wave form

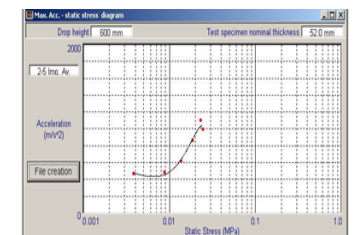

Cushion Curve from some experimental data

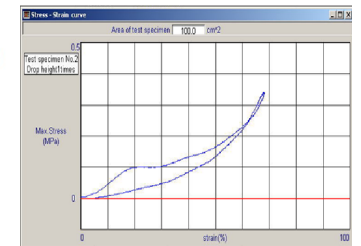

Stress-Strain curve

Specification

Model	ACST-200
Specimen max size (mm)	220 × 220
Fall weight (kg)	Lightweight type : 2.3 ~ 10.0 Heavyweight type : 5.0 ~ 50.0
Max acceleration (m/s ²)	3000 (300G)
Max drop height (mm)	1200
Size (W × D × H mm)	W565 × D740 × H2730
Capacity (kg)	480
Controller Size (W × D × H mm)	W575 × D750 × H1220
Power supply	AC200V, 3-phases, 5A

Options

Velocity measuring device VS-2	Measurement of velocity of dropped weight
Analysis software for cushion characteristics CCA-Win	<ul style="list-style-type: none"> • Acceleration / Displacement - Time History • Cushion factor - Dynamic Stress Diagram • Maximum Acceleration - Static Stress Diagram • Maximum Displacement - Static Stress Diagram

MATERIAL TESTING SYSTEM

CT series

Compression Tester for Packaging

CT-1000, CT-1200

Corrugated box encounters static compression hazards during stack storage in a warehouse with long periods of time. To prevent issues such as bucking or collapse of stacked boxes, compression tests have to be performed.

Features

Multiple Testing Modes

- A compression mode with constant speed and a creep mode is selectable.

Easy operation

- Via user friendly PC software, everyone can conduct the compression test with easy. All testing results, load, displacement, etc. is displayed and stored on PC.

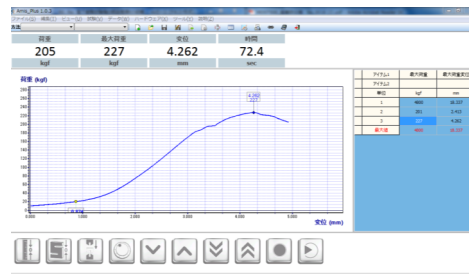

PC Software screen

Compliance Standard

ISO 2872/ ISO 12048/ JIS Z0212

Specification

Model	CT-1000-2	CT-1000-5	CT-1200-2	CT-1200-5
Testing space (W × D × H mm)	1000 × 1000 × 900		1200 × 1200 × 1000	
Testing load (kN)	20 (2000kgf)	50 (5000kgf)	20 (2000kgf)	50 (5000kgf)
Compression speed (mm/min)	0.1 ~ 300			
Motor type	Servo motor			
Compressive platen	Universal Joint			
Safety function	Safety limiter of platen, Emergency button, Earth leakage breaker			
PC connection	TCP / IP (LAN)			
Power (single phase)	AC200 ~ 240V, 5A	AC200 ~ 240V, 8A	AC200 ~ 240V, 5A	AC200 ~ 240V, 8A
Size (W × D × H mm)	1590 × 1000 × 1700		1790 × 1200 × 1760	
Weight (kg)	800	850	900	950
Control PC software	Windows 7 / 10 (32 / 64 bit) * PC sold separately			

Options

Power transformer	AC100V compatible
PC	Selling separately

TRANSPORTATION TESTER

BF-50UT

Transportation Tester

BF-50UT

BF-50UT is able to reproduce the 3-axis (X · Y · Z) simultaneous vibration similar to real transportation conditions and simulate left-right turns by a truck. It only takes 20 minutes to reproduce conditions equivalent to distances of 1000km by truck. Up to 50kg load capacity can be evaluated. This tester is suitable for reproducing the rubbing of outer packaging or contents during transportation.

Features

- Reproduce the triaxle vibration which is equivalent to the vibration on the truck
- Compact design doesn't need for specialized construction Installation space requires only 1 m³
- Vibration generator of fixed amplitude type

Application

- Evaluation of vibration resistance of packaging
- Rubbing test of the inner and outer packaging of products



Specification

Model	BF-50UT
Vibration direction	3-axis simultaneous vibration (up / down, right / left, front / rear)
Adjustable displacement range (mmP-P)	0.2 ~ 2.6
Vibration table size (mm)	500 × 600 with L type jig
Frequency range (Hz)	10 ~ 67 (0.1 Hz increments)
Acceptable acceleration range (m/s ²)	98 (10G)
Maximum loading weight (kg)	50
Operation mode	MANUAL / RANDOM / SWEEP / TRANSPORTATION
Temperature (°C)	0 ~ 40 (No condensing)
Power source	AC200 ~ 240V, 3 phases, 50 / 60Hz, 2A or below
Size (W × D × H mm)	500 × 600 × 650
Capacity (kg)	approx. 80
Standard accessory	3-Dimensional wireless vibration recorder / 1 set

TRANSPORTATION TESTER BF-100UT

Transportation Tester for Large Equipment

BF-100UT

BF-100UT can reproduce the 3-axis (X · Y · Z) simultaneous vibration similar to real transportation conditions and simulate the left-right turn of a truck. It has a greater capacity table that enables it to test large equipment up to 120kg and evaluate multiple samples under the same conditions. This tester is suitable for verification of outer packaging friction by loading test objects in parallel.

Features

- Correspond to vibration test of large equipment.
- Simultaneous evaluation of multiple samples
- No need for specialized construction / Just use leveler to install

Application

- Evaluation of vibration resistance of packaging
- Rubbing test of the inner and outer packaging of products



Specification

Model	BF-100UT
Vibration direction	3-axis simultaneous vibration (up / down, right / left, front / rear)
Adjustable displacement range (mmP-P)	0.4 ~ 2.5
Vibration table size (mm)	1000 × 800 with L type jig
Frequency range (Hz)	10 ~ 50 (0.1 Hz increments)
Acceptable acceleration range (m/s ²)	49 (5G)
Maximum loading weight (kg)	120
Operation mode	MANUAL / RANDOM / SWEEP / TRANSPORTATION
Temperature (°C)	0 ~ 40 (No condensation)
Supply Air Pressure (MPa)	0.4 ~ 0.6 (4 ~ 6kgf/cm ²)
Power source	AC200 ~ 240V, 3phases, 50 / 60Hz, 10A or below
Size (W × D × H mm)	1000 × 800 × 445
Capacity (kg)	approx. 180
Controller size (W × D × H mm)	650 × 460 × 900 *Height of a signal tower is not included
Controller capacity (kg)	approx. 60
Standard accessory	3-Dimensional wireless vibration recorder / 1 set *PC is not included

SHOCK MANAGER™

High Speed Shock Testing System

Hardware: SMH-12, Software: SMS-500

With various functions, SM-500 surely helps in the analysis of shock and vibration acceleration to drive rationalization and cost reduction forward in the line of physical distribution, manufacturing and development. It can incorporate a max. 10 channels of accelerometers and monitor multiple points of shock.

Features

- Multi-channel monitoring , max. 10 channels*
 - Three-way acceleration composite waveform
 - High performance analysis
- SR, SRS, cushioning material characteristics, etc.
 - Digital filter function
 - Specified waveforms display
- * 10 channels on only the piezoelectric or build-in amplifier type
Each 5 channels on the piezoelectric and build-in amplifier type (Total 10 channels)

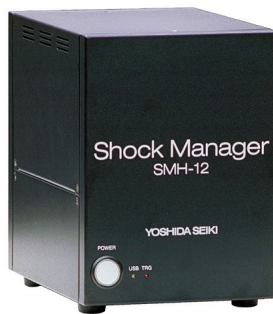

Front of SMH-12



Back of SMH-12

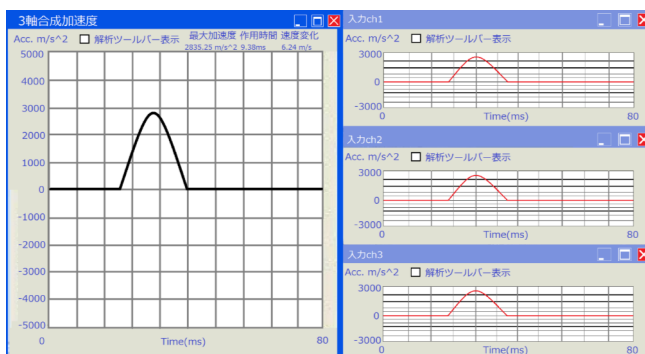

Three-way acceleration waveform

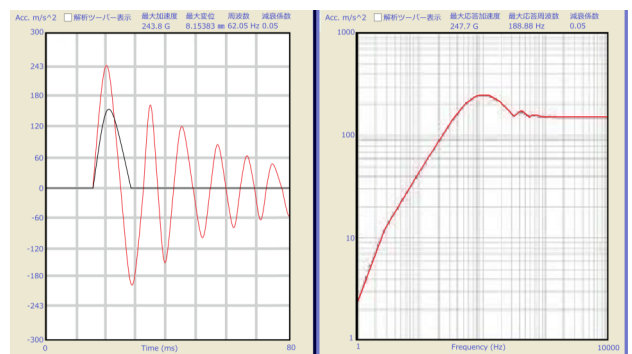

SR/SRS Analysis



Compliance Standard

- JEDEC JESD-22-B111
- MIL-STD-202, 750, 810, 883
- ISO/IEC 17025

Equipped with calculation control function

With our shock testing system (HDST, MDST and ASQ), SMS-500 can calculate the most appropriate condition like effective drop height from the arbitrary shock acceleration and its duration.

Hardware specification

Model	SMH-12	
Availability of channels *	Strain gauge type	1 channel
	Voltage	1 channel (DC±100V)
	Piezoelectric type	5 or 10 channels
	Built-in amplifier piezoelectric type	5 or 10 channels
A/D Convertor	Channels	Max 12 channels
	Sampling rate	Max 1MHz
	Resolution	16bit
Size (W × D × H mm)	150 × 200 × 200	
Power supply	AC100 ~ 240V	
Interface	USB1.1	
Operation environment	temperature : 0 ~ 40°C humidity : below 85 % (No condensing)	

*Piezoelectric type and built-in amplifier piezoelectric type can combine every 5 channels

Software specification

Model	SMS-500	
Measurement function	Processable waveform : Half-sine / Trapezoidal / Sawtooth / Rectangular wave / Triangular wave	
	Number of channel : 12	
	Acceleration measuring range : 1.0 ~ 980000m/s ² (0.1 ~ 100000G)	
	Duration measuring range : 0.01 ~ 99.99ms	
	Speed variation measuring range : 0.01 ~ 99.99m/s	
	Measurement error : ±1% or below	
Digital filter function	Available for each channel	
	Automatic processing (variable from 5 to 20 times of the fundamental waveform)	
	Arbitrary setting : 0.01 ~ 100000Hz (arbitrary changeable even after data is recorded)	
Evaluation function	SR / SRS analysis	
	Creation of fundamental waveforms	
	Displacement analysis	
	3 axis acceleration synthesis function	
Data output	Automatic report creation (Word output), conversion of each data text	
Recommended PC	OS : Windows 2000/7/10 (32/64bit)	
	Main memory 256 MB or more, HDD 100 MB or more free space, CD-ROM drive, USB port	

ACCELERATION MEASUREMENT AccStick

Shock & Vibration Data Logger

AccStick

This extremely small device with built-in 3D accelerometer, flash-memory and rechargeable battery has been released. 3D acceleration waveforms are captured via high speed sampling, at 1600Hz max. Measured data can be described and converted to .csv file via PC software.

Features of hardware

Wide measuring range

2 accelerometers built in to a single unit enable measurements of the accurate behavior of 3D acceleration from 2G to 400G.

High speed sampling

Acceleration waveform in detail is captured by Max 1600Hz sampling rate.

Small package

The extremely small unit, 32.4 x 21.0 x 10.5mm, will enable you to measure 3D acceleration in any location.

Calibration Service (optional)

To measure 3D acceleration with high accuracy, we provide you optional calibration service. Test report & traceability chart will be attached with your device.

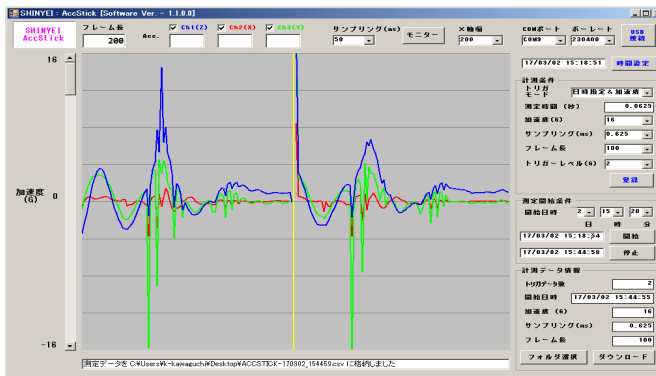
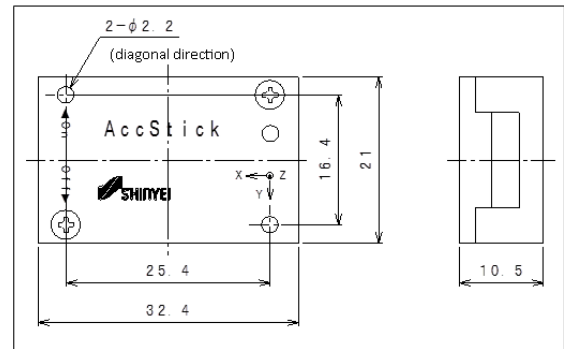
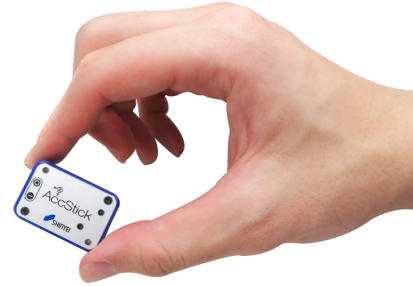

Operation page

Features of software

Original dedicated software provides easy connectivity to PC for parameter settings. Data from data logger is easily transferred to PC and can be conveniently converted to .CSV format. Converted data could be easily studied and analyzed in .CSV format via Microsoft Excel or equivalent.

< Features >

Configuring measuring conditions, Starting or stopping measuring, Downloading measured data, Converting as csv file, Viewing captured data, Monitoring data real time, etc.

⇒ Software is available for free download via website below.

http://www.shinyei-tm.com/product_AccStick.html

Application

- Various automotive applications
- Reliability testing for electrical products
- Motion monitoring for robots and androids
- Logistical distribution such as during loading and unloading, and distribution
- Sporting goods development
- Production equipment monitoring and maintenance

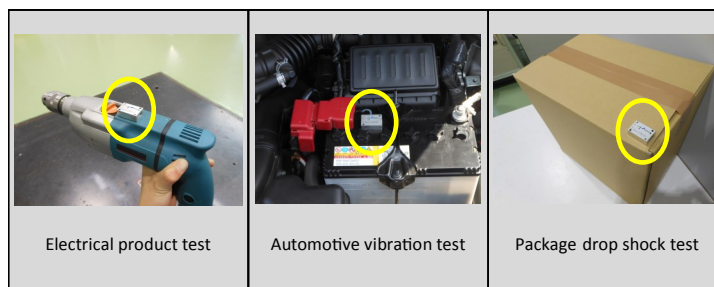

Recommended setting conditions for each application

Vibration

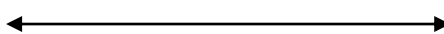

Shock

Setting items \ Measuring subject	Maintenance for mechanical equipment	Vibration test	Ride quality evaluation on the vehicles	Measuring vibration of vehicular parts	Motion monitoring of human body	Drop test for packaging	Measuring of rotational object
Trigger mode	Acceleration Timer & Acceleration	Acceleration Timer & Acceleration	Timer	Timer	Timer	Timer	Timer
Measuring time (s)	1.25	1.25	312.5	312.5	625	125	250
Acceleration range (G)	8	16	2	16	16	100	16 ~
Sampling rate (ms)	0.625	0.625	0.625	0.625	1.25	1.25	1.25
Flame length	2,000	2,000	500,000	500,000	500,000	100,000	200,000
Trigger level	2	2	—	—	—	—	—

Specification

Product	Shock & Vibration data logger AccStick	
model	A01-16400	
Accelerometer	Vibration sensor	± 16G with 3axis MEMS
	Shock sensor	± 400G with 3axis MEMS
Configuration range (G)	Vibration sensor	2 / 4 / 6 / 8 / 16
	Shock sensor	100 / 200 / 400
	Accuracy	± 5% F.S.
Sampling period (ms)	0.625 ~ 160 (selectable, 0.625ms is for vibration sensor only. ± 5% accuracy.)	
Flame	100 ~ 500000 (selectable)	
Trigger mode	Immediate / Timer / Acc. / Timer & Acc.	
Memory	4MB Flash memory (up to 500000 data)	
Power	Lithium polymer rechargeable battery (full charge time : about 60 minutes)	
Duration	Up to 72 hours (Acc. trigger mode at 20°C with full charge) *depend on temperature, measuring or battery condition	
Size (mm)/ weight (g)	W32.4 × D21.0 × H10.5 / 15	
Case material	Aluminium (with two M2 screw fixing holes)	
Operational temperature (°C)	0 ~ +60 (No condensing)	
PC software	Measuring configuration, data download, csv file output	OS : Windows7/10 (32/64bit)
Accessory	Dedicated cable for AccStick, micro USB cable	

FIELD DATA RECORDER

DER-1000

Field Data Logger

DER-1000

DER-1000 is tri-axial data recorder for drop tests, measuring vibration, temperature / humidity in transportation continuously max.100 days by large capability 1GB memory. Recorded data is available for multiple analyses, such as drop height, PSD, histogram, transportation check-up and PSD composition. Users can select High Spec. version or Normal Spec. version.

Features

- Built in tri-axial acceleration sensor and temperature & humidity sensor.
- Long term measurement for a maximum of 100days.
*lithium battery x 4, 25°C (depending on measuring condition settings)
- Memory capacity 1GB.
- Dead time zero recording
- Two different versions (Normal spec. or High spec., should be selected when ordering).

Application

- Distribution environment survey of package freight, and quality control.
- Development of standards for package freight drop test and vibration test.
- Development of packaging specification.
- Finding problems in distribution environment.
- Distribution traceability survey.



Specification

Model	High Spec	Normal Spec
Memory size	1GB	16MB
Continuous record time *	Maximum 100 days	Maximum 70 days
Trigger mode	Acceleration / Time / W trigger	Acceleration
Frame length	512 / 1024 / 2048 / 4096	1024 / 2048
Sampling (ms)	0.25 / 0.35 / 0.5 / 1 / 2 / 5 / 10 / 20	0.5 / 1 / 2
Acceleration measurement	Tri-axial piezoelectric type (5 / 10 / 25 / 50G Acceleration range switchable)	
Temperature & humidity	Temperature : -20 ~ 60°C, Humidity : 0 ~ 100% rh	
Battery	9V battery × 4 (max.), parallel connection	
Interface	USB	
Size (mm)	W121 × D109 × H58	
Weight (g)	950	
Case material	Aluminum	
OS	Windows 7 / 10 (32 / 64bit)	
Operating environment (°C)	-20 ~ 60 (No condensing)	
Option	GPS matching	

*Lithium battery x 4, 25°C(depends on measuring condition setting)

FIELD DATA RECORDER

FIR-106

Shock Recorder

FIR-106

Shock recorder FIR-106 is a pen recording styled data logger that can capture vibration of products during transport. Handling is so easy that you can record shock clearly in any position and read it directly. Power supply is not required.

Features

- Guaranteed precision at all times by performance test.
- Continuous recording of about 3000 times automatically.
- Easy-to-use in any condition due to the compact size.
- Clear lines will be drawn on the recording paper in any position.
- Gridlines are printed on the recording paper.
- Data is drawn at m/s^2 so you can read it directly without correction or translation.

Application

- Recording the shock that product suffered during transport.
- Monitoring the transport vehicle and loading.
- Self-monitoring for transport insurance purposes.



Specification

Model	FIR-106	
Measurement direction	1 axis	
Range of measurement (m/s^2)	± 50 ($\pm 5G$)	± 100 ($\pm 10G$)*
Recording sensitivity ($mm/(m/s^2)$)	0.3	0.14
Natural frequency (Hz)	30	40
Measuring frequency range (Hz)	0 ~ 20	0 ~ 25
Recording method	Scratch recording	
Printed paper	Stylus paper (including acceleration scale)	
Paper – driven method	Automation	
Paper – driven (m/s^2)	Over ± 5	Over ± 10
Size (W × D × H mm)	109 × 94 × 64	
Weight (kg)	0.7	
Power supply	Not necessary	

FIELD DATA RECORDER

G-MEN series

Acceleration & Impact Recorder

DR01, DR20, DR100

G-MEN is one of the field data recorders with simple functions and has a MEMS type tri-accelerometer and temperature & humidity sensor, lasting up to 50 days by AA battery. There are 3 models that are 2G, 20G and 100G for selection. All devices have a LCD display that can show you the measured peak acceleration immediately. Measured data can be shown and output as csv file via an analysis software on PC .

Features

- Built in tri-axial acceleration sensor and temperature & humidity sensor.
- Continuous measurement for up to 50days at 10ms sampling *AA size alkaline battery x 2.
- Memory capacity 65500 point.
- Three different models.
(DR01 for 2G, DR20 for 20G, DR100 for 100G)

Application

- Distribution environment survey of package freight, and quality control.
- Finding problem in distribution environment.
- Distribution traceability survey.



Specification

Model	DR01	DR20	DR100
Acceleration Range (G)	1 / 2 (changeable)	10 / 20 (changeable)	100
Frequency Range (Hz)	DC ~ 100	DC ~ 100	16 ~ 100
Resolution (G)	0.01 (at 1G) 0.02 (at 2G)	0.1 (at 10G) 0.2 (at 20G)	1
Memory size	65500 points		
Continuous record time	Maximum 50 days (at 10ms sampling, depends on temperature environment / battery performance)		
Sampling rate (ms)	1 / 2 / 5 / 10 / 20		
Temperature & humidity	Temperature : 0 ~ 50°C, Humidity : 30 ~ 90% rh		
Battery	AA battery × 2		
Interface	USB mini-B		
Size (mm)	W60.5 × D33.0 × H75.5		
Weight (g)	135 (include battery)		
OS for software	Windows 7 (32 / 64bit)		
Operating environment (°C)	0 ~ 50 (non condensing)		



SHINYEI TESTING MACHINERY CO., LTD.

Head Office B47-11, Katoridai, Tsukuba, Ibaraki, 300-2657, JAPAN
Tel: +81-29-848-3571 FAX: +81-29-848-3572

International Sales Office

Shinyei BLDG. 5F, 77-1 Kyomachi, Chuo-ku, Kobe 651-0178, JAPAN
Tel: +81-78-392-6903 FAX: +81-78-332-1619

<http://www.shinyei-tm.com>

Specification and information listed in this catalog are subject to change without notice.

Affiliate

SHINYEI KAISHA ELECTRONICS (M) SDN. BHD.

No.313, Lot2557, 6 1/2Miles, Jalan Skudai, 81200 Johor Bahru, Johor, Malaysia

TEL. +60-7-2386017 FAX. +60-7-2386022

SHINYEI CORP. of AMERICA

1120 Avenue of the Americas 4th Floor New York, NY 10036 U.S.A.

TEL. +1-212-626-2676 FAX. +1-917-398-7050